

TECH MESH - FILL PANELS

PANEL	QTY	LENGTH (L)	WIDTH (W)	MESH
A				
B				
C				
D				

SHOWN WITH WELDED WIRE

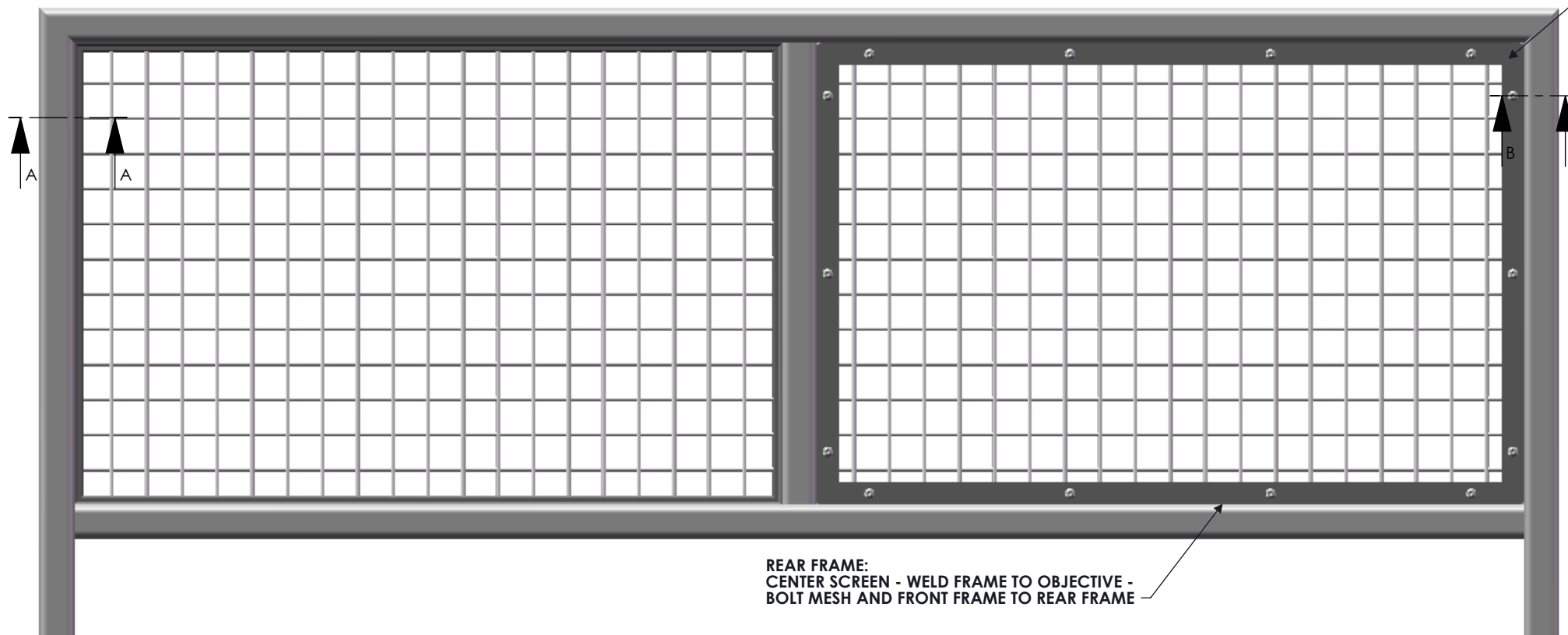
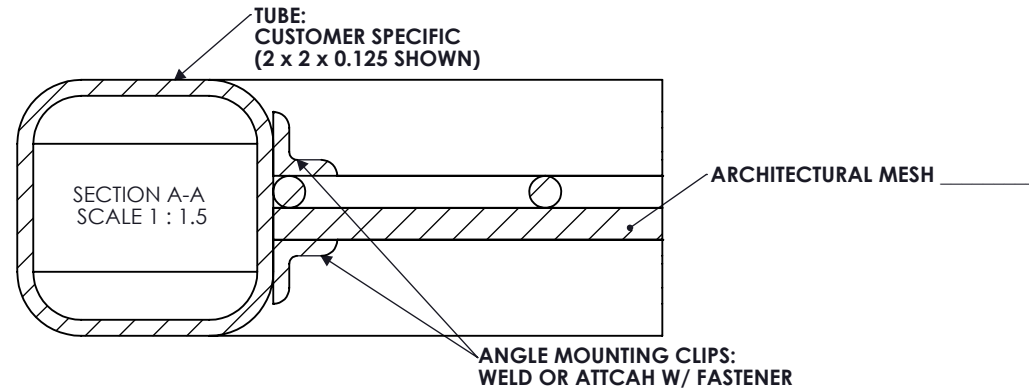
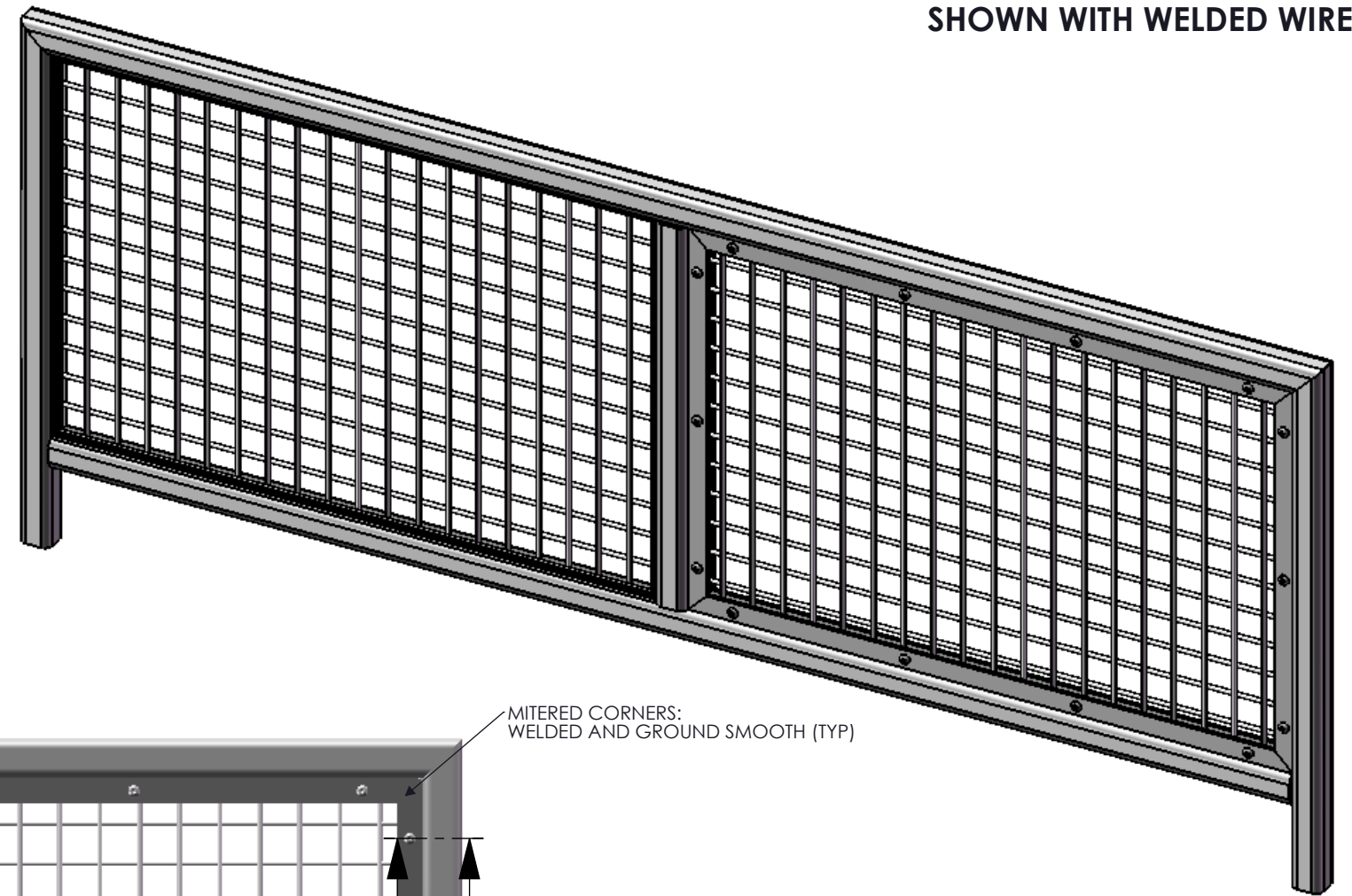

MITERED CORNERS: WELDED AND GROUND SMOOTH (TYP)

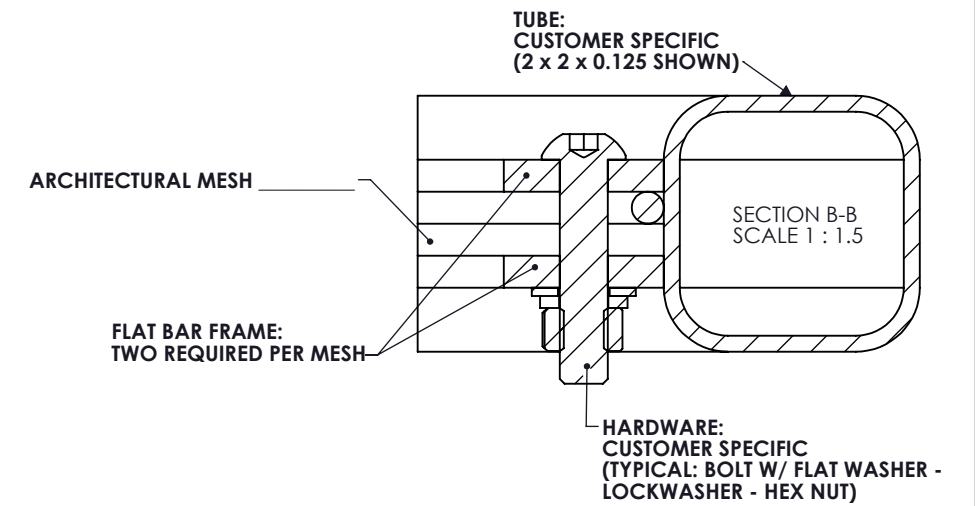

THE WESTERN GROUP CLAIMS PROPRIETARY RIGHT IN THE INFORMATION DISCLOSED HEREIN. IT IS AGREED THAT ANY AND ALL SPECIFICATIONS, DATA AND DESIGN CONCEPTS SHOWN SHALL REMAIN CONFIDENTIAL WITH THE SPECIFIC UNDERSTANDING THAT NEITHER THIS DRAWING NOR ANY REPRODUCTION THEREOF WILL BE DISCLOSED TO OTHERS NOR USED FOR THE PURPOSE OF MANUFACTURE NOR PROCUREMENT NOR THE ARTICLE NOR PART SHOWN HEREIN WITHOUT PRIOR WRITTEN CONSENT OF THE WESTERN GROUP.

UNLESS OTHERWISE SPECIFIED:
 DIMENSIONS ARE IN INCHES
 TOLERANCES:
 FRACTIONAL $\pm 1/32$
 ANGULAR: MACH $\pm 1/2^\circ$
 TWO PLACE DECIMAL ± 0.015
 THREE PLACE DECIMAL ± 0.005



THE WESTERN GROUP
 4025 N.W. EXPRESS AVE.
 PORTLAND, OR 97208 (503)222-1644

TITLE: **TECH MESH - FILL PANELS**

MATERIAL	DATE:	SIZE B	DWG. NO. TWG-TM-102B	REV
FINISH	SCALE: 1:10	DRAWN BY: JRK	CHECKED BY:	SHEET 1 OF 1

REVISIONS			
REV.	DESCRIPTION	DATE	APPROVED

DO NOT SCALE DRAWING